

European Union Directives (CE)

In This Appendix. . . .

- European Union (EU) Directives
 - Basic EMC Installation Guidelines
-

European Union (EU) Directives



NOTE: The information contained in this section is intended as a guideline and is based on our interpretation of the various standards and requirements. Since the actual standards are issued by other parties and in some cases Governmental agencies, the requirements can change over time without advance warning or notice. Changes or additions to the standards can possibly invalidate any part of the information provided in this section.

This area of certification and approval is absolutely vital to anyone who wants to do business in Europe. One of the key tasks that faced the EU member countries and the European Economic Area (EEA) was the requirement to harmonize several similar yet distinct standards together into one common standard for all members. The primary purpose of a harmonized standard was to make it easier to sell and transport goods between the various countries and to maintain a safe working and living environment. The Directives that resulted from this merging of standards are now legal requirements for doing business in Europe. Products that meet these Directives are required to have a CE mark to signify compliance.

Member Countries Currently, the members of the EU are Austria, Belgium, Denmark, Finland, France, Germany, Greece, Ireland, Italy, Luxembourg, The Netherlands, Portugal, Spain, Sweden, and the United Kingdom. Iceland, Liechtenstein, and Norway together with the EU members make up the European Economic Area (EEA) and all are covered by the Directives.

Applicable Directives There are several Directives that apply to our products. Directives may be amended, or added, as required.

- **Electromagnetic Compatibility Directive (EMC)** — this Directive attempts to ensure that devices, equipment, and systems have the ability to function satisfactorily in their electromagnetic environment without introducing intolerable electromagnetic disturbance to anything in that environment.
- **Machinery Safety Directive** — this Directive covers the safety aspects of the equipment, installation, etc. There are several areas involved, including testing standards covering both electrical noise immunity and noise generation.
- **Low Voltage Directive** — this Directive is safety related and covers electrical equipment that has voltage ranges of 50–1000VAC and/or 75–1500VDC.
- **Battery Directive** — this Directive covers the production, recycling, and disposal of batteries.

Compliance Certain standards within each Directive already require mandatory compliance, such as the EMC Directive, which has gained the most attention, and the Low Voltage Directive.

Ultimately, we are all responsible for our various pieces of the puzzle. As manufacturers, we must test our products and document any test results and/or installation procedures that are necessary to comply with the Directives. As a machine builder, you are responsible for installing the products in a manner which will ensure compliance is maintained. You are also responsible for testing any combinations of products that may (or may not) comply with the Directives when used together.

The end user of the products must comply with any Directives that may cover maintenance, disposal, etc. of equipment or various components. *Although we strive to provide the best assistance available, it is impossible for us to test all possible configurations of our products with respect to any specific Directive. Because of this, it is ultimately your responsibility to ensure that your machinery (as a whole) complies with these Directives and to keep up with applicable Directives and/or practices that are required for compliance. **CE conformity will be impaired if the recommended installation guidelines are not met.***

Currently, the DL05, DL06, DL205, DL305, DL405 and Terminator I/O systems manufactured by Koyo Electronics Industries, FACTS Engineering or Host Engineering, when properly installed and used, conform to the Electromagnetic Compatibility (EMC) and Low Voltage Directive requirements of the following standards.

- **EMC Directive Standards Relevant to PLCs and Terminator I/O**
 - EN50081-1 Generic immunity standard for residential, commercial, _____ and light industry (DL05 only at this time)
 - EN50081-2 Generic emission standard for industrial environment.
 - EN50082-1 Generic immunity standard for residential, commercial, _____ and light industry
 - EN50082-2 Generic immunity standard for industrial environment.
 - **Low Voltage Directive Standards Applicable to PLCs and Terminator I/O**
 - EN61010-1 Safety requirements for electrical equipment for _____ measurement, control, and laboratory use.
 - **Product Specific Standard for PLCs and Terminator I/O**
 - EN61131-2 Programmable controllers, equipment requirements and tests. This standard replaces the above generic standards for immunity and safety. However, the generic emissions standards must still be used in conjunction with the following standards:
 - EN 61000-3-2—Harmonics
 - EN 61000-3-2—Fluctuations
- Automationdirect.com** is currently in the process of changing their testing procedures from the generic standards to the product specific standard, so that all new products will be tested to standard EN61131-2. Check our catalog or website for updated information.

Special Installation Manual

The installation requirements to comply with the requirements of the Machinery Directive, EMC Directive and Low Voltage Directive are slightly more complex than the normal installation requirements found in the United States. To help with this, we have published a special manual which you can download from our website: www.automationdirect.com

- **DA-EU-M** – EU Installation Manual that covers special installation requirements to meet the EU Directive requirements. Download this manual to obtain the most up-to-date information.

Other Sources of Information

Although the EMC Directive gets the most attention, other basic Directives, such as the Machinery Directive and the Low Voltage Directive, also place restrictions on the control panel builder. Because of these additional requirements it is recommended that the following publications be purchased and used as guidelines:

- BSI publication TH 42073: February 1996 – covers the safety and electrical aspects of the Machinery Directive
- EN 60204-1:1992 – General electrical requirements for machinery, including Low Voltage and EMC considerations

- IEC 1000-5-2: EMC earthing and cabling requirements
- IEC 1000-5-1: EMC general considerations

It may be possible for you to obtain this information locally; however, the official source of applicable Directives and related standards is:

The Office for Official Publications of the European Communities
L-2985 Luxembourg; quickest contact is via the World Wide Web at
www.euro-op.eu.int

Another source is:

Global Engineering Documents
www.global.ihs.com

Basic EMC Installation Guidelines

Enclosures

The following diagram illustrates good engineering practices supporting the requirements of the Machinery and Low Voltage Directives. House all control equipment in an industry standard lockable steel enclosure and use metallic conduit for wire runs and cables. The diagram applies to all **DirectLOGIC** PLC systems and Terminator I/O systems.

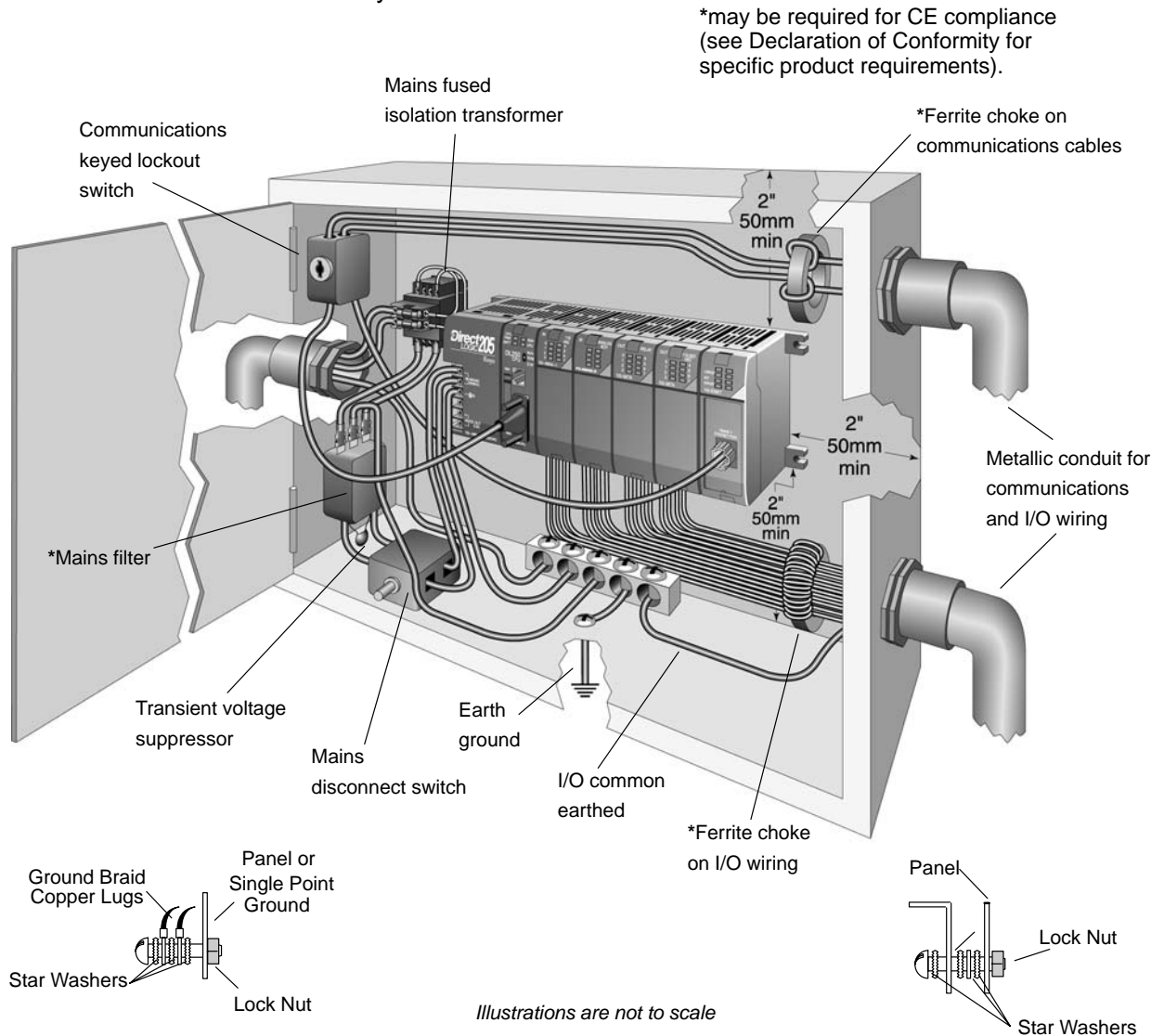

Electrostatic Discharge (ESD)

We specify in all declarations of conformity that our products are installed inside an industrial enclosure using metallic conduit for external wire runs; therefore, we test the products in a typical enclosure. However, we would like to point out that although our products operate normally in the presence of ESD, this is only the case when mounted within an enclosed industrial control cabinet. When the cabinet is open during installation or maintenance, the equipment and or programs may be at risk of damage from ESD carried by personnel.

We therefore recommend that all personnel take necessary precautions to avoid the risk of transferring static electricity to components inside the control cabinet. If necessary, clear warnings and instructions should be provided on the cabinet exterior, such as recommending the use of earth straps or similar devices, or the powering off of equipment inside the enclosure.

Suppression and Fusing

In order to comply with the fire risk requirements of the Low Voltage and Machinery Directive electrical standards EN 61010-1, and EN 60204-1, by limiting the power into “unlimited” mains circuits with power leads reversed, it is necessary to fuse both AC and DC supply inputs. You should also install a transient voltage suppressor across the power input connections of the PLC or Terminator I/O. Choose a suppressor such as a metal oxide varistor, with a rating of 275VAC working voltage for 230V nominal supplies (150VAC working voltage for 115V supplies) and high energy capacity (eg. 140 joules).

Transient suppressors must be protected by fuses and the capacity of the transient suppressor must be greater than the blow characteristics of the fuses or circuit breakers to avoid a fire risk. A recommended AC supply input arrangement for Koyo PLCs and Terminator I/O systems is to use twin 3 amp TT fused terminals with fuse blown indication, such as DINnectors DN-F10L terminals, or twin circuit breakers, wired to a Schaffner FN2010 filter or equivalent, with high energy transient suppressor soldered directly across the output terminals of the filter. PLC and Terminator I/O system inputs should also be protected from voltage impulses by deriving their power from the same fused, filtered, and surge-suppressed supply.

Internal Enclosure Grounding

A heavy-duty star earth terminal block should be provided in every cubicle for the connection of all earth ground straps, protective earth ground connections, mains filter earth ground wires, and mechanical assembly earth ground connections. This should be installed to comply with safety and EMC requirements, local standards, and the requirements found in IEC 1000-5-2. The Machinery Directive also requires that the common terminals of PLC or Terminator I/O input modules, and common supply side of loads driven from PLC or Terminator I/O output modules should be connected to the protective earth ground terminal.

Equi-potential Grounding

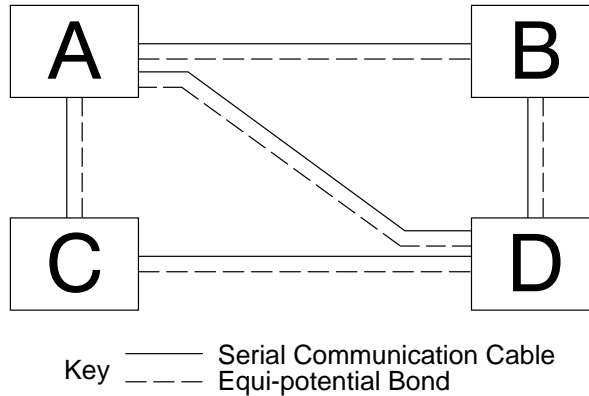

Adequate site earth grounding must be provided for equipment containing modern electronic circuitry. The use of isolated earth electrodes for electronic systems is forbidden in some countries. Make sure you check any requirements for your particular destination. IEC 1000-5-2 covers equi-potential bonding of earth grids adequately, but special attention should be given to apparatus and control cubicles that contain I/O devices, remote I/O racks, or have inter-system communications with the primary PLC or Terminator I/O system enclosure. An equi-potential bond wire must be provided alongside all serial communications cables, and to any separate items of the plant which contain I/O devices connected to the PLC or Terminator I/O system. The diagram shows an example of four physical locations connected by a communications cable.

Communications and Shielded Cables

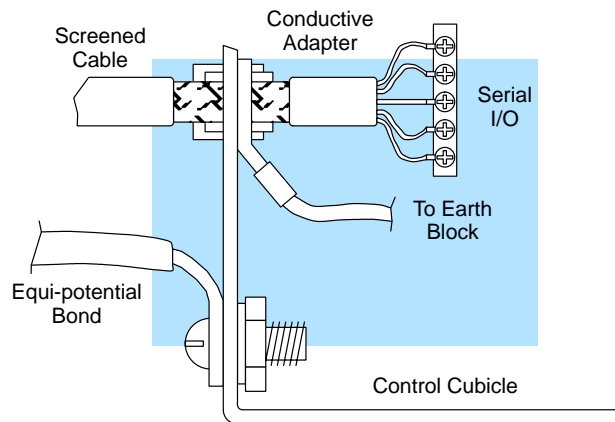

Good quality 24 AWG minimum twisted-pair shielded cables, with overall foil and braid shields are recommended for analog cabling and communications cabling outside of the PLC or Terminator I/O enclosure.

To date it has been a common practice to only provide an earth ground for one end of the cable shield in order to minimize the risk of noise caused by earth ground loop currents between apparatus. The procedure of only grounding one end, which primarily originated as a result of trying to reduce hum in audio systems, is no longer applicable to the complex industrial environment. Shielded cables are also efficient emitters of RF noise from the PLC or Terminator I/O system, and can interact in a parasitic manner in networks and between multiple sources of interference.

The recommendation is to use shielded cables as electrostatic “pipes” between apparatus and systems, and to run heavy gauge equi-potential bond wires alongside all shielded cables. When a shielded cable runs through the metallic wall of an enclosure or machine, it is recommended in IEC 1000-5-2 that the shield should be connected over its full perimeter to the wall, preferably using a conducting adapter, and not via a pigtail wire connection to an earth ground bolt. Shields must be connected to every enclosure wall or machine cover that they pass through.

NOTE: Cables, whether shielded or not **MUST** be enclosed within earthed metal conduit or other metallic trunking when outside the PLC or Terminator I/O enclosure.



Analog and RS232 Cables

Providing an earth ground for both ends of the shield for analog circuits provides the perfect electrical environment for the twisted pair cable as the loop consists of signal and return, in a perfectly balanced circuit arrangement, with connection to the common of the input circuitry made at the module terminals. RS232 cables are handled in the same way.

Multidrop Cables

RS422 twin twisted pair, and RS485 single twisted pair cables also require a 0V link, which has often been provided in the past by the cable shield. It is now recommended that you use triple twisted pair cabling for RS422 links, and twin twisted pair cable for RS485 links. This is because the extra pair can be used as the 0V inter-system link. With loop DC power supplies earth grounded in both systems, earth loops are created in this manner via the inter-system 0v link. The installation guides encourage earth loops, which are maintained at a low impedance by using heavy equi-potential bond wires. **To account for non-European installations using single-end earth grounds, and sites with far from ideal earth ground characteristics, we recommend the addition of 100 ohm resistors at each 0V link connection in network and communications cables.**

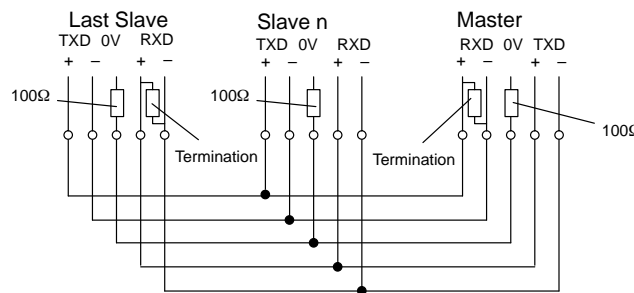

Shielded Cables within Enclosures

When you run cables between PLC or Terminator I/O items within an enclosure which also contains susceptible electronic equipment from other manufacturers, remember that these cables may be a source of RF emissions. There are ways to minimize this risk. Standard data cables connecting PLCs, Terminator I/O or operator interfaces should be routed well away from other equipment and their associated cabling. You can make special serial cables where the cable shield is connected to the enclosure’s earth ground at both ends, the same way as external cables are connected.

Network Isolation

For safety reasons, it is a specific requirement of the Machinery Directive that a keyswitch must be provided that isolates any network input signal during maintenance, so that remote commands cannot be received that could result in the operation of the machinery. The FA-ISONET does not have a keyswitch. Use a keylock and switch on your enclosure which when open removes power from the FA-ISONET. To avoid the introduction of noise into the system, any keyswitch assembly should be housed in its own earth grounded steel box and the integrity of the shielded cable must be maintained.

Again, for further information on EU directives we recommend that you get a copy of our EU Installation Manual (DA-EU-M). Also, if you are connected to the World Wide Web, you can check the EU Commission's official site at: <http://eur-op.eu.int/>

Items Specific to Terminator I/O

- This equipment must be properly installed while adhering to the guidelines of the PLC or Terminator I/O installation manual DA-EU-M, and is suitable for EN 61010-1 installation categories 1 or 2.
- The rating between all circuits in this product are rated as **basic insulation only**, as appropriate for single fault conditions.
- The protection provided by the equipment may be impaired if the equipment is used in a manner not specified by the manufacturer.
- It is the responsibility of the system designer to earth one side of all control and power circuits, and to earth the braid of screened cables.
- Input power cables must be externally fused and have an externally mounted switch or circuit breaker, preferably mounted near the Terminator I/O system.
- When needed, carefully clean the outside plastic case of Terminator I/O components using a dry cloth.
- Only use replacement parts supplied by **Automationdirect.com** or its agents.
- Cables, whether shielded or not **MUST** be enclosed within earthed metal conduit or other metallic trunking when outside the Terminator I/O enclosure.
- This is a Class A product and it may cause radio interference in certain environments. The user may need to provide shielding, or other measures to eliminate the interference.